

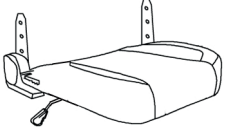

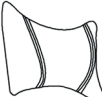

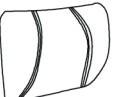





<b>A</b> x1 	<b>B</b> x1 
<b>C</b> x1 	<b>D</b> x1 
<b>E</b> x5 	<b>F</b> x1 
<b>G</b> x1 	<b>H</b> x1 
<b>I</b> x12 Screws (mechanism) 	<b>J</b> x2 
<b>K</b> x2 Screws (side mechanism) 	<b>L</b> x2 
<b>M</b> x1 Spanner 	<b>N</b> x1 

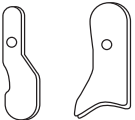

**EN****MAINTENANCE GUIDE**

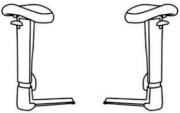
- Pull the levers up to adjust the height and recline of the chair.
- Do not attempt to recline the chair with the anti-recline safety activated to prevent damage.
- Be careful when adjusting the angle of the backrest to avoid violent movements of the backrest.
- Any use of this product beyond that intended for sitting will be classified as misuse of the product and may result in breakage and/or injury to the user.
- Do not sit on the back of the chair. Avoid tilting the chair while it is lying down, this could cause damage to the structure of the chair.
- This chair is designed for one person at a time.
- Don't sit on the armrests.
- Avoid exposing the chair to direct sunlight or other sources of heat.
- All parts should be checked regularly to ensure they are safe for use.

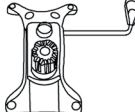
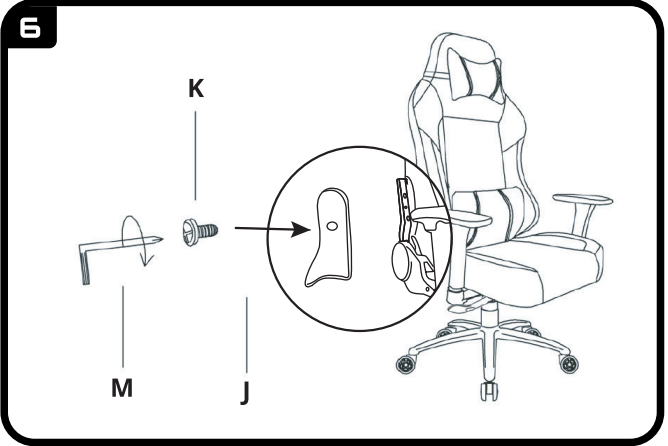
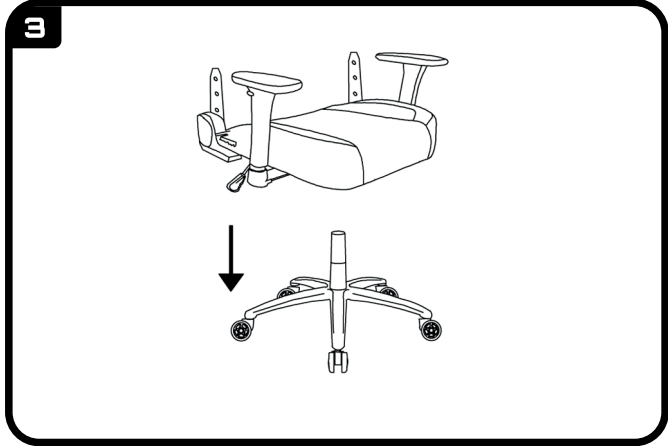
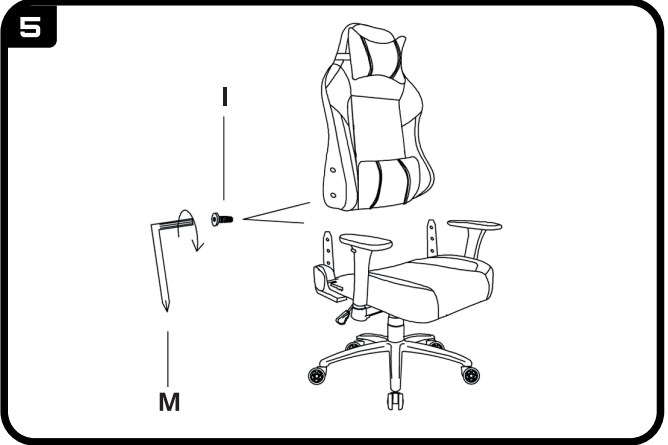
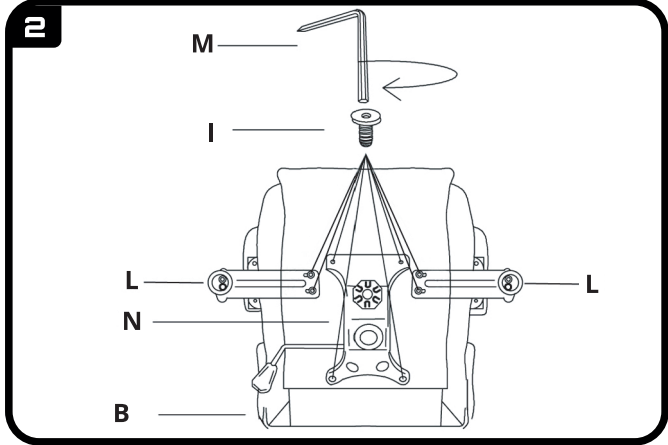
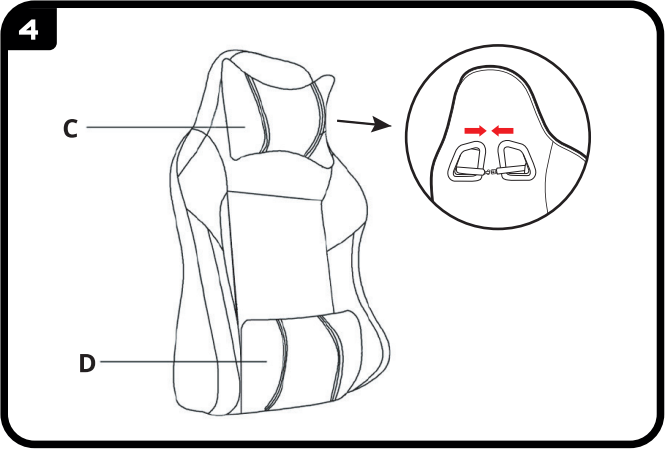
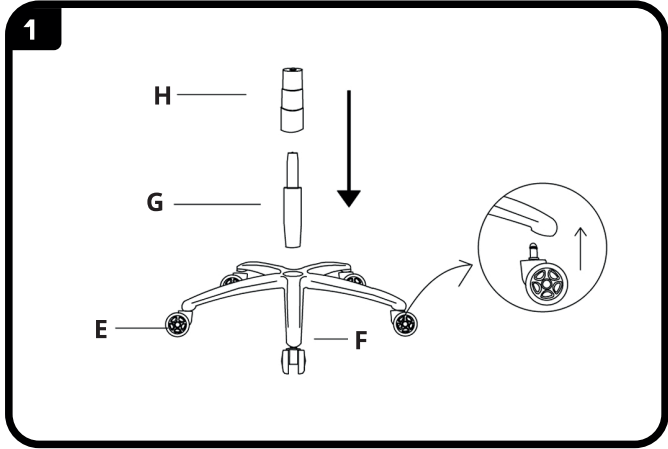
**MORE INFO**

- Type of chair: Type C
- Casters suitable for any type of surface
- Adjusting mechanisms: reclining backrest and adjustable seat height
- Warning! Only trained personnel may replace or repair components for height adjustment of seating furniture with energy storage.
- Stop using the chair immediately if you discover that it is damaged.
- Do not open or attempt to open the seat cover zipper.

**CHAIR CLEANING AND MAINTENANCE**

- Use mild cleaners if necessary. Do not rub excessively.
- Do not use solvents or abrasive cleaning products.

**LEATHERETTE CLEANING**

- Most stains are removed when using water and a microfiber cloth, or just gently wipe the surface with a non-abrasive sponge with a solution of soap and warm water or a mild liquid detergent.
- Stop using the chair immediately if you discover that it is damaged.
  - Do not open or attempt to open the seat cover zipper.

**CLOTH CLEANING**

Vacuum the backrest and seat of the chair regularly. Rub the fabric gently with a brush at dirty spots. You can use a water-based detergent with a steam vacuum or a dry-cleaning detergent, but don't get the fabric too wet.

**WHEELS CLEANING**

Rotate the chair and make sure it is securely held by the seat and backrest. Vacuum the debris and use a damp microfiber cloth to wipe off wheels' outer dirt.